



wavebrite™

INSTALLATION & OPERATING INSTRUCTIONS

WWW.WAVEBRITE.CO.UK

WWW.WAVESTREAM.CO.UK

Contents Wavebrite™ Installation, Operation and Cartridge Replacement Instructions

Section	Page
1. Introduction	2
1.1 Important	2
1.2 What It Does	2
1.3 About these instructions	3
1.4 Before you begin	3
2. Tools and Fasteners	3
3. Basic Components	4
4. Wavebrite™ Grey Water Filter System Specifications Fig 1.	4
5. Installing the Components	5
6. Cartridge Replacement	6
7. Functional Checks	6
7.1 Installation check	6
7.2 With pump running, check	6
7.3 Operational / Maintenance check	7
8. Code of Practice	7

Section 1. Introduction

1.1 Important

It is important to us that this product works as advertised and that you enjoy the extra peace of mind that Wavebrite™ offers by protecting the environment. If you have any queries that can not be answered by your supplier or engineer, please contact us direct on +44 (0) 1476 861717 or e-mail info@wavebrite.co.uk or info@waveinternational.co.uk

1.2 What it does

- The Wavebrite™ grey water filter system removes contaminants from waste water which is pumped through the system before discharge overboard or being reused. Grey waste water is generally produced by showers, hand basins and washing machines. The system is controlled by a float switch located in the WHALE GREY WASTE WATER SUMP which switches the pump on and off. This filter system is designed to remove contaminants from grey water, if galley waste is put through the system cartridge life could be drastically reduced.
- Wavebrite™ is designed for used in all sizes of boat and can easily be scaled up for larger boats and Superyachts. The Wavebrite filter modules can be installed in multiples in parallel if the flow rate and contamination level is high. Differential pressure indicates when the filters and main Wavebrite™ filter module need changing, see Section 1.4 Check with Wave International technical department if in doubt.
- As an additional feature, a Gulper Pump from Whale (not supplied) can be installed to the WHALE GREY WASTE WATER SUMP to provide direct pump out should it be required in areas where it is permitted.

CAUTION

This filter system is designed to remove contaminants from grey water, if galley waste is put through the system cartridge life could be drastically reduced.

1.3 About these instructions

The panels on the left of the pages draw attention to SAFETY CONSIDERATIONS of the adjacent text in accordance with the conventions of the EU Recreational Craft Directive.

DANGER

- DANGER. Indicates a hazard that could easily result in death or serious injury if proper precautions are not taken. If you have any doubts about what precautions to take, you should seek expert advice.

WARNING

- WARNING. Indicates a hazard that could result in death or serious injury if proper precautions are not taken. If you have any doubts about what precautions to take, you should seek expert advice.

CAUTION

- CAUTION. Indicates a hazard that could result in personal injury or damage to your boat or its equipment if suitable care is not taken.

NOTE

- NOTE. Contains additional information that may be of help.

1.4 Before you begin

CAUTION

If you have any doubts at any time about installing this equipment, please consult a qualified person or contact Wave International for advice.

Before you start, please read through these instructions carefully. Fitting Wavebrite™ involves:

- Cutting in to a section of flexible hose or grey waste water discharge pipe. Making electrical connections.
- Installing Wavebrite™ into the grey waste water discharge system usually using hose tails and clamps, it may also require screwing into a threaded section of pipe or using flanged and bolted fittings which are not supplied. Electrical connections should be made by a qualified electrical installer with reference to the electrical equipment suppliers instructions.
- Mounting the Wavebrite™ filter module, pre-filters, pump strainer, pump and grey waste water sump by bolting or screwing the mounting brackets to a solid fixing point.
- The position you mount the Wavebrite™ filter module, pre-filters and pump filter/strainer in must allow for cartridge replacement. Do not mount in direct sunlight.
- **Some consideration must be given at this time to location of the components, the following all affect pump performance:**
- Suction hose length between the pump strainer, grey waste sump and the pump. If too long this can reduce pump performance.
- Hose diameter and type, correct hose is supplied from the WHALE GREY WASTE WATER SUMP.
- Discharge head from the pump should be less than 1000 mm
- Angles and fittings in hoses all cause a reduction in pump efficiency.
- The shorter the pipe runs to and from the WAVEBRITE™ FILTER MODULE with no extra fittings such as elbows and bends, the better the system will perform. Always check with the Wave International Technical Department if in doubt.

WARNING

Electrical connections are required and should be carried out by and checked by a qualified electrical installer.

Section 2. Tools and Fasteners

WARNING

See Whale Pipe Fitting Guide regarding the Whale WX 15mm pipe. Take care if using a sharp knife to cut the 25mm flexible hose.

Wavebrite™ can be installed with the average DIY toolkit. Items you will need:

- Fixings/bolts for filter, pump and tank brackets.
- Electrical connections, switches, fuses and wire. See Section 1.4 and Fig.2
- Thread tape or thread sealing compound.
- Suitable pipe cutter (prt. No. WX7950) for the Whale WX 15mm pipe as shown in the Whale Catalogue. See Whale Pipe Fitting Guide supplied.



Section 3. Basic Components

NOTE

Fixings & electrical connections to install in to the boat are not supplied and will need to be obtained prior to fitting. See **Sections 2. & 5.**

Before you start, please check that your system kit contains the following components. If you think you are short of any items, please call us immediately.

Wavebrite™ Complete System

<u>Item</u>	<u>Qty.</u>	<u>Description</u>
1.	1	WAVEBRITE™ FILTER MODULE.
2.	2	Saddle clamps for WAVEBRITE™ FILTER MODULE
3.	1	WAVEBRITE WB1 CARTRIDGE™ installed.
4.	1	Filter housing with 5 micron wound cartridge.
5.	1	Filter housing with 0.5 micron wound cartridge.
6.	1	Filter housing with 100 micron screen.
7.	3	Tees for pressure gauges with quick connect.
8.	3	Pressure gauges.
9.	1	Hour Meter.
10.	1	15mm Quick Connect for WAVEBRITE™ FILTER MODULE
11.	3	Stainless steel brackets.
12.	12	Filter housing bracket screws
13.	1	WHALE UNIVERSAL WATER PUMP 12 or 24 volt.
14.	1	WHALE GREY WASTE WATER SUMP 16L.
15.	5 Mtrs	15 mm hose.
16.	1 Mtrs	25 mm braided hose.
17.	4	Hose clips
18.	1	Instruction and information pack.

Refer to Whale Water Systems Catalogue for further information regarding **WHALE PUMPS** and the **WHALE GREY WASTE WATER SUMP +44 (0)28 9127 0531 info@whalepumps.com www.whalepumps.com**

Section 4. Wavebrite™ Grey Water Filter System Specifications

FLOW RATE:	1-15 Liters per min.
SYSTEM MAX. PRESSURE:	6.2 bar.
PRE-FILTERS MAX. DIFF. PRESSURE:	2 bar. (@ 2 bar. change cartridge)
WAVEBRITE MODULE MAX. DIFF. PRESSURE:	4 bar. (@ 4 bar. change cartridge)
MAX. TEMP:	45 deg. C.
MIN. TEMP:	1 deg. C.
WAVEBRITE WB1 CARTRIDGE:	Part No. WB1
WOUND CARTRIDGE:	Part No. WP10P0.5 (0,5 micron)
WOUND CARTRIDGE:	Part No. WP10P5 (5 micron)
FILTER SLEEVE:	Part No. SFSN10100 (100 micron)

Leave a minimum of **25 mm** below each filter housing to allow cartridge removal.

Leave a minimum of **660 mm** at one end of the WAVEBRITE™ FILTER MODULE.

Fig 1.

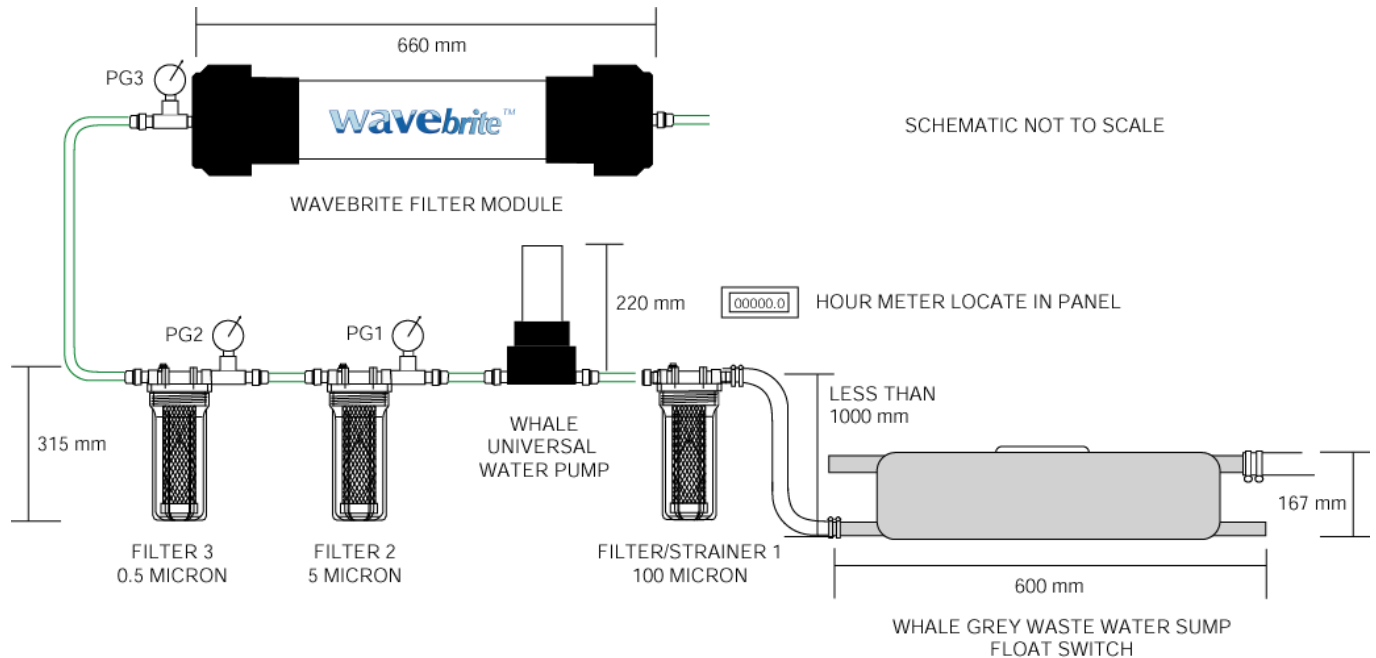

Section 5. Installing the Components

Fitting Wavebrite™. See Fig 1.

CAUTION

It is advisable to use two hose clamps on hose tails, so each connection is double clamped.

NOTE

Refer to Whale Water Systems Catalogue for further information if required.

whalepumps.com

WARNING

Electrical connections are required and to be carried out by and checked by a qualified marine electrical installer.

- Locate a suitable position, refer to Section 1.4 and Fig.1. Note the Wavebrite™ system is modular and each component can be fitted remotely. Fix the mounting brackets and saddle clamps. The FILTER/STRAINER 1 will require the most attention and should be installed where it can be easily monitored visually and can be accessed with ease.
- Attach the filter housings to the mounting brackets using the screws provided; ensuring the flow direction is correct; there are arrows on the top filter housings and on the WHALE UNIVERSAL WATER PUMP. The arrows must point in the direction of flow from the WHALE GREY WASTE WATER SUMP towards the WAVEBRITE™ FILTER MODULE. The flow direction through the WAVEBRITE™ FILTER MODULE is left to right, but this can be changed by reversing the WAVEBRITE WB1 CARTRIDGE in the WAVEBRITE™ FILTER MODULE housing if required, note flow direction arrow on WAVEBRITE WB1 CARTRIDGE.
- Connect from the exit of Filter Strainer 1 to the pump and all the filters to the WAVEBRITE™ FILTER MODULE with the 15mm hose supplied, quick connect fittings are supplied. **See the Whale Pipe Fitting Guide supplied in the information pack.**
- The WHALE GREY WASTE WATER SUMP should be located so the head to the pump is no more than 1000mm and the required pipe connections must be pre-drilled. The grey water supply, such as from showers and basins are to go to the top connections, no hose or hose clips are supplied for this. Connect from the lower 25mm connection to the Filter Strainer 1 using the 25mm flexible braided hose, 2 no. hose clips should be used on each end, these are supplied. **Note, that galley sink waste should be directed to the black water system due to the food waste content and if directed to the Wavebrite system it may significantly reduce cartridge life.**
- It is required to have enough space below the filter units (25mm) to remove the filter bowls when changing cartridges and at one end of the WAVEBRITE™ FILTER MODULE (660mm) **check the system specifications at Section 4 above.**
- Install the Tees and pressure gauges using thread tape.
- Make the electrical connections to the pump, hour meter and WHALE GREY WASTE WATER SUMP as per the instructions supplied with the electrical components and to required safety standards. Locate the hour meter in a panel or an appropriate position. All electrical connections to be carried out by and checked by a qualified marine electrical installer. **See section 5.1 Fig 2.**

5.1 Wiring Diagram Fig 2.

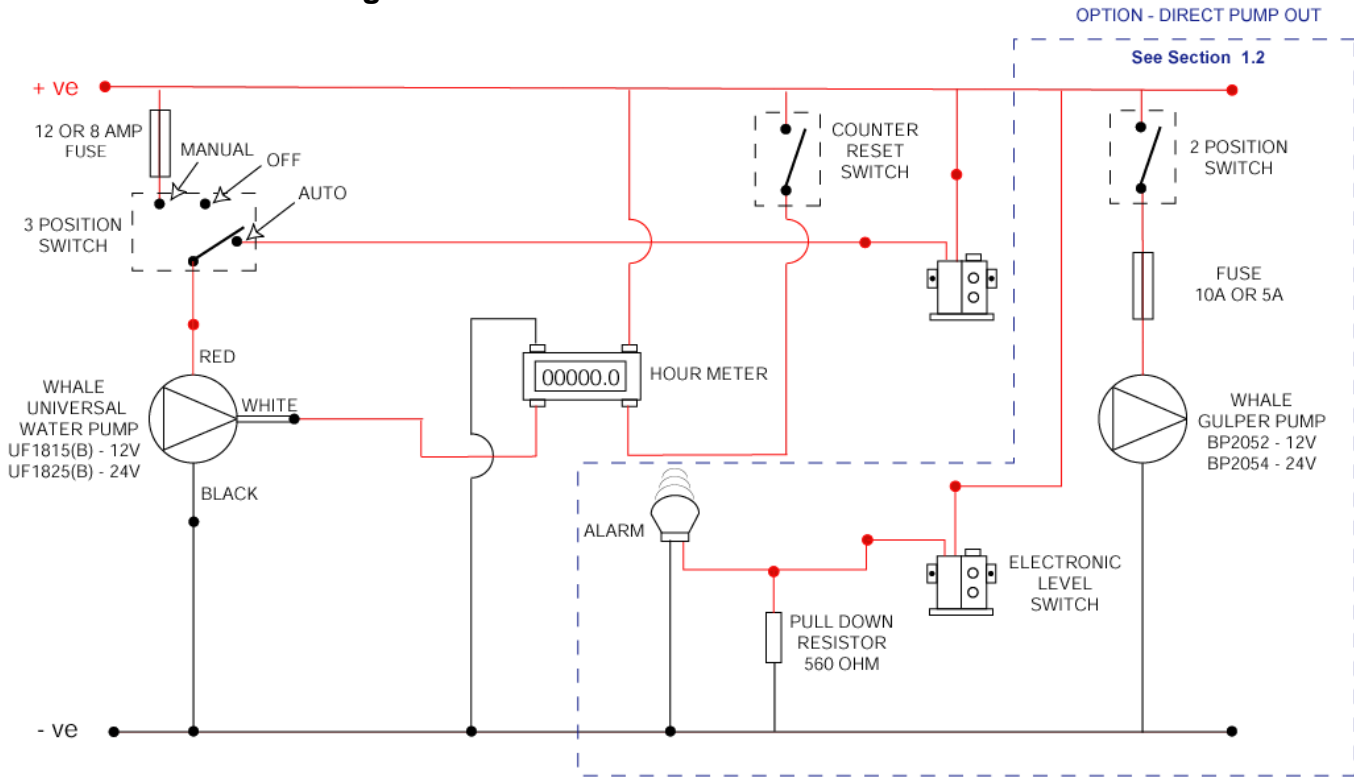

Section 6. Cartridge Replacement

WARNING

Before replacing the cartridges ensure the pump is switched off and there is no pressure in the system.

CAUTION

When replacing the filter bowls hand tighten only

WARNING

Place saturated cartridges in a suitable receptacle for responsible onward disposal

IMPORTANT. Before replacing the cartridges ensure the pump is switched off and there is no pressure in the system.

- **FILTER/STRAINER 1 (100 MICRON) screen requires cleaning periodically and should be part of a regular maintenance schedule.** If the strainer becomes blocked pump performance will be significantly reduced and cause the flow in the complete system to drop.
- **The filter cartridge in FILTER 2 (5 MICRON) requires changing when the differential pressure between gauges PG1 & PG2 reaches 2 bar during pumping.**
- **The filter cartridge in FILTER 3 (0.5 MICRON) requires changing when the differential pressure between gauges PG2 & PG3 reaches 2 bar during pumping.**
- When replacing the filter bowls hand tighten only.
- Ensure the pump is switched off.
- Unscrew the filter bowl and pour the excess water remaining in the bowl back in to the grey or black water system. Plastic spanners can be supplied and should only be used to remove the filter bowls they should be replaced by hand and only hand tight.
- **The WAVEBRITE™ FILTER MODULE requires changing after 20 hours of operation. Also change if pressure gauge PG3 reaches 4 bar during pumping.** It is opened by removing the plastic circular clip releasing the end cap which can then be removed allowing the removal of the WAVEBRITE™ WB1 CARTRIDGE
- Remove the saturated cartridges placing them in a suitable receptacle for onward disposal.
- Check the 'O' rings on the outside and inside of the end cap are in good condition.
- Locate new cartridge in the WAVEBRITE™ FILTER MODULE and replace end cap securely.
- Turn on the pump by running water into the grey water system and bleed any air from the filter housings using the bleed button, check for any leaks.

Section 7. Functional Checks

7.1 Installation Check

WARNING

Electrical connection should be carried out by and checked by a qualified marine electrical installer.

- Go over all your work one last time, ensuring that:
 - The clamps securing the flexible hose are fully tightened.
 - All connections are tight.
 - Electrical connection to be checked by a qualified marine electrical installer.
 - Make sure any other components you disturbed or removed during the fitting process have been refitted correctly.

WARNING

Check the filters and pressure gauges regularly. Debris in the water can affect the performance of the system.

7.2 With Pump Running Check

- If fitted check the pump discharge valve is OPEN.
- Pump is controlled by the float switch in the WHALE GREY WASTE WATER SUMP, run water through the system and check for leaks.

7.3 Operational / Maintenance Check

DANGER

Before opening filter housings ensure the pump is switched off and there is no pressure in the system

- IMPORTANT.** Before opening filter housings ensure the pump is switched off and there is no pressure in the system.
- Apart from making cartridge changes as described in **Section 6**, make cartridge replacements part of a regular maintenance programme at the end of the season or after periods of heavy use.
- Galley sink waste should be directed to the black water system due to the food waste content, if directed to the Wavebrite™ system it may significantly reduce cartridge life and filter checks must be made more frequently.

Section 8. Code of Practice

Some points to remember

- Make sure all grey water lines and connections are in good order and are not leaking.
- Regularly check filter gauge pressure during operation.
- Where possible prevent particulate or fibrous materials from entering the grey water system.
- If the additional by-pass pump is fitted ensure direct pump out from the WHALE GREY WASTER WATER SUMP is permitted and reinstate the Wavebrite System as soon as possible.
- Take ashore in proper containers any Wavebrite™ system cartridges to be disposed of at approved facilities at marinas, lock stations or local authority waste disposal sites.
- As far as possible, use biodegradable detergents, soaps and cleaning materials.

Wave International Limited
Axholme House
Newton Way
Colsterworth
Grantham NG33 5NP
UK

Your local agent is:

tel.: +44 1476 861717
fax: +44 1476 861817
email: info@wavebrite.co.uk
www.wavebrite.co.uk
www.wavestream.co.uk

All the Wavebrite™ products in this document meet the requirements of the Recreational Craft Directive at 1st January 2000

Wavebrite™ is a Wave International Limited Trade Mark

Wave International limited makes no representations or warranties with respect to the contents or use of this manual and specifically disclaims any express or implied warranties of merchantability or fitness for any particular purpose. Further, Wave International Limited reserves the right to revise this publication and make changes to its content, at any time and to make changes to any and all parts of Wave International products without obligation to notify any person or entity of such revisions or changes.